



Features

- Fast, easy-to-use TEACH-Mode programming; no potentiometer adjustments
- Scalable output automatically distributes the output signal over the width of the programmed sensing window.
- Minimum and Maximum window limits can be adjusted independently.
- Selectable 0 to 10V dc or 4 to 20 mA output, selected via DIP-switch
- Access to bank of 8 DIP switches through sealed cover for superior user functionality
- Rugged encapsulated design for harsh environments
- Unique housing design allows for multiple mounting configurations.
- Choose models with integral 2 m (6.5') or 9 m (30') cable, or with Mini-style or Euro-style quick-disconnect fitting
- Wide operating range: -20° to +70°C (-4° to +158°F)
- Temperature compensation
- Programmable for either positive or negative output slope



Models

Models	Sensing Range	Cable*	Supply Voltage	Output
QT50ULB	200 mm to 8 m (8" to 26")	5-wire, 2 m (6.5') cable	10 to 30V dc	Selectable: 0 to 10V dc or 4 to 20 mA
QT50ULBQ		5-pin Mini-style QD		
QT50ULBQ6		5-pin Euro-style QD		

* NOTES:

- 9 m cables are available by adding suffix "w/30" to the model number of a cabled sensor (e.g., QT50ULB w/30).
- A model with a QD connector requires a mating cable; see page 10.

Information about discrete-output models is available on Banner's website: www.bannerengineering.com



WARNING . . . Not To Be Used for Personnel Protection

Never use these products as sensing devices for personnel protection. Doing so could lead to serious injury or death.

These sensors do NOT include the self-checking redundant circuitry necessary to allow their use in personnel safety applications. A sensor failure or malfunction can cause either an energized or de-energized sensor output condition. Consult your current Banner Safety Products catalog for safety products which meet OSHA, ANSI and IEC standards for personnel protection.

U-GAGE™ QT50U Series Sensor — Analog Output

Principles of Operation

Ultrasonic sensors emit one or multiple pulses of ultrasonic energy, which travel through the air at the speed of sound. A portion of this energy reflects off the target and travels back to the sensor. The sensor measures the total time required for the energy to reach the target and return to the sensor. The distance to the object is then calculated using the following formula:

$$D = \frac{ct}{2}$$

D = distance from the sensor to the target

c = speed of sound in air

t = transit time for the ultrasonic pulse

To improve accuracy, an ultrasonic sensor may average the results of several pulses before outputting a new value.

Temperature Effects

The speed of sound is dependent upon the composition, pressure and temperature of the gas in which it is traveling. For most ultrasonic applications, the composition and pressure of the gas are relatively fixed, while the temperature may fluctuate.

In air, the speed of sound varies with temperature according to the following approximation:

$$C_{m/s} = 20 \sqrt{273 + T_C}$$

$C_{m/s}$ = speed of sound in meters per second

T_C = temperature in °C

Or, in English units:

$$C_{ft/s} = 49 \sqrt{460 + T_F}$$

$C_{ft/s}$ = speed of sound in feet per second

T_F = temperature in °F

The speed of sound changes roughly 1% per 6° C (10° F). QT50U series ultrasonic sensors have temperature compensation available, via the 8-pin DIP switch. Temperature compensation will reduce the error due to temperature by about 90%.

NOTE: If the sensor is measuring across a temperature gradient, the compensation will be less effective.

Analog Output Slope

The U-GAGE QT50U sensor may be programmed for either a positive or a negative output slope, depending on which conditions are taught for the Min and Max Analog limits (see Figure 1). If the Min Analog limit is the Near Window setting and the Max Analog limit is the Far Window setting, then the slope will be positive. If the opposite is true, then the slope will be negative.

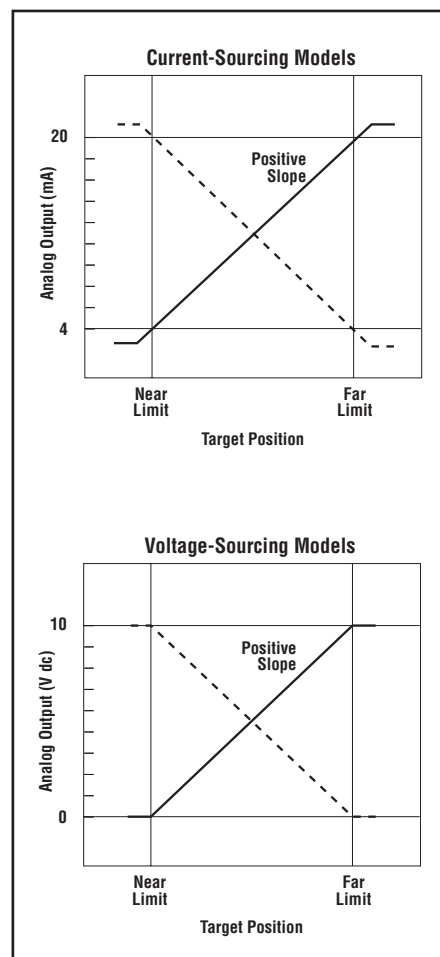
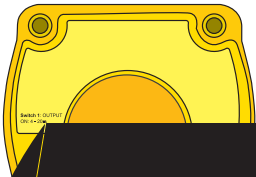

Figure 1. Positive and negative output slopes

U-GAGE™ QT50U Series Sensor — Analog Output



U-GAGE™ QT50U Series Sensor — Analog Output

DIP-Switch-Selectable Functions

Switch 1: Output Mode Select

- ON = 4 to 20 mA current output is enabled
- OFF = 0 to 10V dc voltage output is enabled

Switch 1 configures the sensor internally to use either the current output or voltage output configuration.

Switch 2: Loss of Echo Mode Select

- ON = Min-Max Mode
- OFF = Hold Mode

Switch 2 determines the output response to the loss of echo. “Min-Max Mode” (Switch 2 ON) drives the output to either the minimum value or the maximum value when the echo is lost. (Minimum or Maximum value is selected via Switch 3.)

“Hold Mode” (Switch 2 OFF) maintains the output at the value which was present at the time of echo loss.

Switch 3: Min-Max Default

- ON = Default to maximum output value at loss of echo (10.5V dc or 20.8 mA)
- OFF = Default to minimum output value at loss of echo (0V dc or 3.6 mA)

Switch 3 selects the output response to loss of echo when “Min-Max Mode” is selected via Switch 2. When Switch 2 is OFF, Switch 3 has no function.

Switch 4: Teach/Transmit Enable Control

- ON = Gray (or yellow) wire configured for remote teach
- OFF = Gray (or yellow) wire configured for transmit enable/disable
 - High (5 to 30V dc):** Transmit Enabled (Power LED solid Green)
 - Low (0 to 2V dc):** Transmit Disabled (Power LED flashes at 2 Hz)

When Switch 4 is ON, the gray wire is used to teach window limits to the sensors.

When Switch 4 is OFF, the gray wire is used to enable and disable the sensor’s transmit burst. The sensor output will react as if a “loss of echo” occurred and either hold the output or change to minimum or maximum value (depending on switch 2 and 3 settings). This function may be used when multiple sensors are in close proximity, which may make them vulnerable to crosstalk interference. A PLC can be used to enable the sensors one at a time to avoid crosstalk.

Switches 5 and 6: Response Speed Adjustment

Switches 5 and 6 are used to set the speed of the output response. The four values for response speed (see DIP switch settings table on page 3) relate to the number of sensing cycles over which the output value is averaged.

Switch 7: Temperature Compensation

- ON = Temperature compensation enabled
- OFF = Temperature compensation disabled

Changes in air temperature affect the speed of sound, which in turn affects the distance reading measured by the sensor. An increase in air temperature shifts both sensing window limits closer to the sensor. Conversely, a decrease in air temperature shifts both limits farther away from the sensor. This shift is approximately 3.5% of the limit distance for a 20° C change in temperature. With temperature compensation enabled

U-GAGE™ QT50U Series Sensor — Analog Output

(Switch 7 ON), the sensor will maintain the window limits to within 1.8 percent over the -20° to +70° C range.

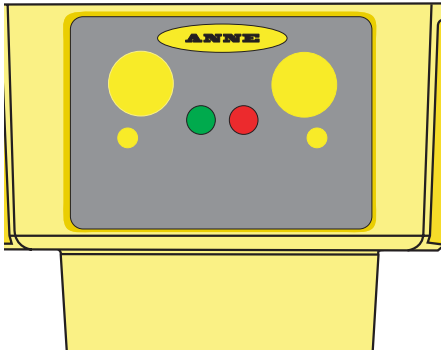

The temperature sensor in the sensor's bezel cannot adapt to temperature change as quickly as an external temperature device can. When there are fast fluctuations in temperature, it may be best to use an external temperature monitor and feed its signal and the uncompensated distance measurement into a controller and perform the compensation calculations within the controller.

Consult the factory for details on performing temperature compensation calculations.

NOTES:

- If temperature compensation is enabled, exposure to direct sunlight can affect the sensor's ability to accurately compensate for changes in temperature.
- With temperature compensation enabled, the temperature warmup drift upon power-up is less than 0.8% of the sensing distance. After 15 minutes, the apparent distance will be within 0.5% of the actual distance. After 30 minutes, the apparent distance will be within 0.3% of the actual distance.

Switch 8: Factory Calibration





ON = Factory calibration only

OFF = Normal operation

U-GAGE™ QT50U Series Sensor — Analog Output

Using the Auto-Window Feature

Teaches a sensing distance threshold centered within a fixed sensing window (a 1 m window centered on the position taught). This procedure centers the analog output on the taught position at approximately 5V dc or 12 mA.

	Push Button		Remote Line	
	Procedure	Result	Procedure 0.04 sec. < T < 0.8 sec.	Result
Auto-Window	<ul style="list-style-type: none"> Push and hold Min Analog  	<ul style="list-style-type: none"> Min Analog LED turns ON Red 	<ul style="list-style-type: none"> Position the target at the location where the midpoint of the window should be. Triple-pulse the remote line 	<ul style="list-style-type: none"> Min and Max LEDs both flash Red (0.5 second), then turn Yellow
	<ul style="list-style-type: none"> “Click” Max Analog  	<ul style="list-style-type: none"> Max Analog LED turns ON Red (Both the Min and Max Analog LEDs should now be ON) 		
	<ul style="list-style-type: none"> Position the target at the location where the midpoint of the window should be. “Click” either push button  	<ul style="list-style-type: none"> Its LED will flash Red. 		
	<ul style="list-style-type: none"> “Click” the other push button  	<ul style="list-style-type: none"> The Red Teach LEDs will change to Yellow and the sensor will return to RUN mode 		

Push Button Lockout

Enables or disables the keypad to prevent anyone on the production floor from adjusting any of the programming settings.

	Push Button		Remote Line	
	Procedure	Result	Procedure 0.04 sec. < T < 0.8 sec.	Result
Push Button Lockout	<ul style="list-style-type: none"> Not available via push button 	<ul style="list-style-type: none"> Not applicable 	<ul style="list-style-type: none"> Four-pulse the remote line 	<ul style="list-style-type: none"> Push buttons are either enabled or disabled, depending on previous condition.

General Notes on Programming

1. The sensor will return to RUN mode if the limit is not registered within 120 seconds after entering TEACH Mode.
2. Press and hold the programming push button > 2 seconds (before teaching the limit) to exit PROGRAM mode without saving any changes. The sensor will revert to the last saved program.
3. If push buttons do not respond, perform remote lockout procedure to enable push buttons.

U-GAGE™ QT50U Series Sensor — Analog Output

Status Indicators

Signal LED

The Red Signal LED indicates the strength and condition of the sensor's incoming signal. See Figure 5.

Signal LED Status	Indicates
ON Bright	Good signal
ON Dim	Marginal signal strength
OFF	<ul style="list-style-type: none"> No signal is received, or Target is beyond the sensor's range limitations

Output LEDs

The Yellow Output/Teach LED indicates the position of the target relative to the window limits. See Figure 5.

Output/Teach LED	Indicates
ON Red (either)	In Teach mode; waiting for limit(s) to be taught
Min Analog ON Yellow Max Analog ON Yellow	Target is within analog window limits
Min Analog ON Yellow Max Analog Flashing Yellow	Target is outside Max window limit
Min Analog Flashing Yellow Max Analog ON Yellow	Target is outside Min window limit
Min Analog OFF Max Analog OFF	<ul style="list-style-type: none"> No signal condition, or Outside operating limits

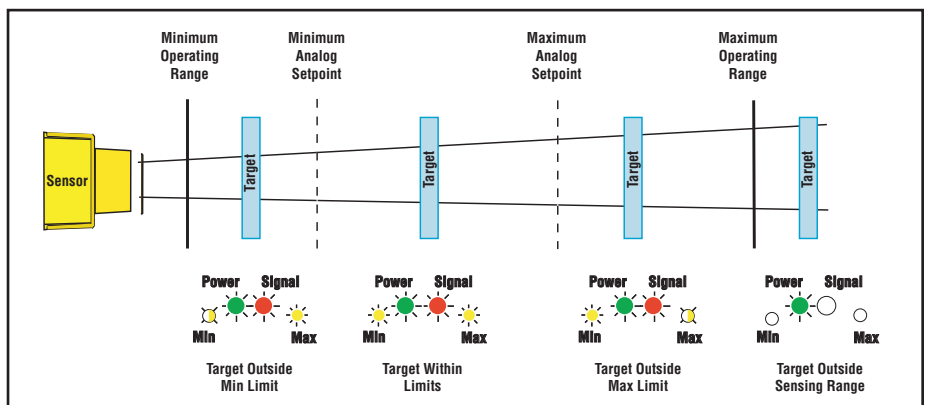

Figure 5. Status indicator conditions for each target position

Power ON/OFF LED

The Green Power ON/OFF LED indicates the operating status of the sensor. See Figure 5.

Power ON/OFF LED	Indicates
OFF	Power is OFF
Flashing @ 2Hz	Transmit disabled (see page 4)
ON Solid	Sensor is operating normally

U-GAGE™ QT50U Series Sensor — Analog Output

QT50U Response Curves

QT50U Effective Beam Pattern

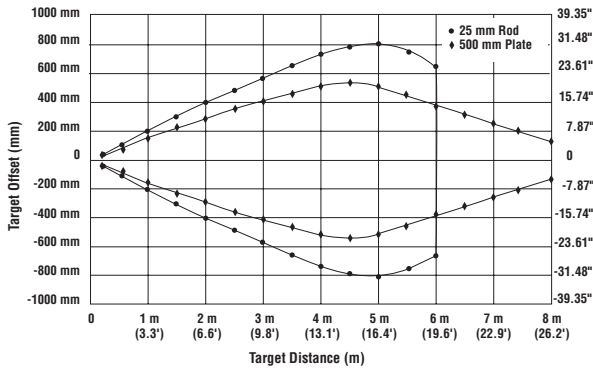

QT50U (with 500 mm Plate) Maximum Target Rotation Angle

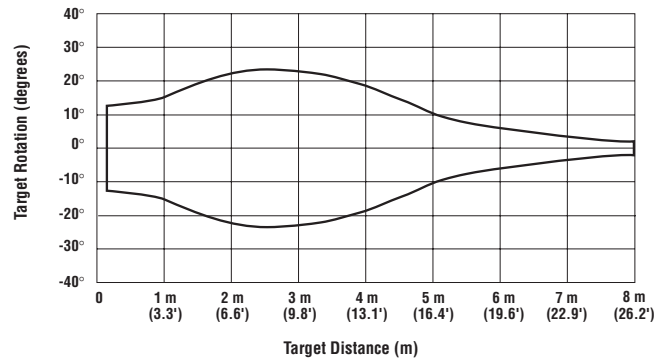

Hookups

Integral Cable Model

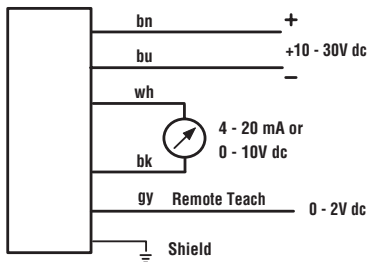

Quick-Disconnect Model (5-pin Mini-Style)

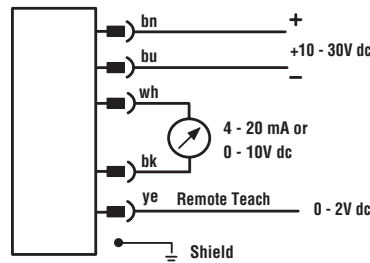

Quick-Disconnect Model (5-pin Euro-Style)

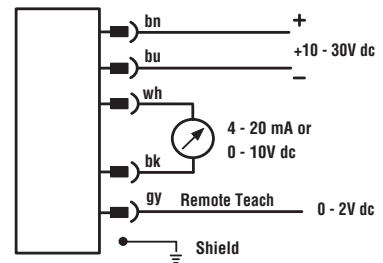

* It is recommended that the shield wire be connected to earth ground or DC common.

U-GAGE™ QT50U Series Sensor — Analog Output

U-GAGE™ QT50U Series Analog Output Model Specifications

Sensing Range	200 mm to 8 m (8" to 26')
Supply Voltage	10 to 30V dc (10% maximum ripple); 100 mA max at 10V, 40 mA max at 30V (exclusive of load)
Ultrasonic Frequency	75 kHz burst, rep. rate 96 ms
Supply Protection Circuitry	Protected against reverse polarity and transient overvoltages
Output Protection	Protected against short circuit conditions
Delay at Power-up	1.5 seconds
Analog Output Configuration	<p>Voltage Sourcing: 0 to 10V dc Minimum Load Resistance = 500 ohms Minimum Required Supply Voltage for Full 0-10V Output Span = $(\frac{1000}{R_{LOAD}} + 13)V$ dc</p> <p>Current Sourcing: 4 to 20 mA Maximum Load Resistance = 1 kΩ or $(\frac{V_{supply}}{0.02} - 5)$ ohms, whichever is lower</p> <p>Minimum required supply voltage for full 4-20 mA output span = 10V dc or $[(R_{LOAD} \times 0.02) + 5]V$ dc, whichever is greater. 4-20 mA output calibrated at 25° C with a 250 Ω load.</p>
Temperature Effect	<p>Uncompensated: 0.2% of distance/°C Compensated: 0.02% of distance/°C</p>
Linearity	+/- 0.2% of span from 200 to 8000 mm; +/- 0.1% of span from 500 to 8000 mm (1 mm minimum)
Resolution	1.0 mm
Output Response Time	100 ms to 2300 ms. See "Switches 5 and 6" in the table on page 3.
Minimum Window Size	20 mm
Adjustments	Sensing window limits: TEACH-Mode programming of near and far window limits may be set using the push buttons or remotely via TEACH input (see page 5).
Indicators	<p>Green Power On LED: Indicates power is ON (see page 7) Red Signal LED: Indicates target is within sensing range, and the condition of the received signal (see page 7) Teach/Output indicator (bicolor Yellow/Red): Yellow – Target is within taught limits Flashing Yellow – Target is outside taught window limits Red – Sensor is in TEACH mode</p>
Remote TEACH	To Teach: Connect gray or yellow wire to 0 to +2V dc; impedance 12k Ω (See page 4 for transmit disable function)
Construction	<p>Transducer: Ceramic/Epoxy composite Housing: ABS/Polycarbonate Membrane Switch: Polyester Lightpipes: Acrylic</p>
Operating Conditions	<p>Temperature: -20° to +70° C (-4° to +158° F) Maximum relative humidity: 100%</p>
Connections	2 m (6.5') or 9 m (30') shielded 5-conductor (with drain) PVC jacketed attached cable or 5-pin Euro-style quick-disconnect or 5-pin Mini-style quick-disconnect
Environmental Rating	Leakproof design is rated IEC IP67; NEMA 6P
Vibration and Mechanical Shock	All models meet Mil Std. 202F requirements. Method 201A (vibration: 10 to 60Hz max., double amplitude 0.06", maximum acceleration 10G). Also meets IEC 947-5-2 requirements: 30G 11 ms duration, half sine wave
Temperature Warmup Drift	Less than 0.8% of sensing distance upon power-up with Temperature Compensation enabled (see Temperature Compensation, pages 4 and 5)
Application Notes	Objects passing inside the specified near limit (200 mm) may produce a false response.

U-GAGE™ QT50U Series Sensor Output

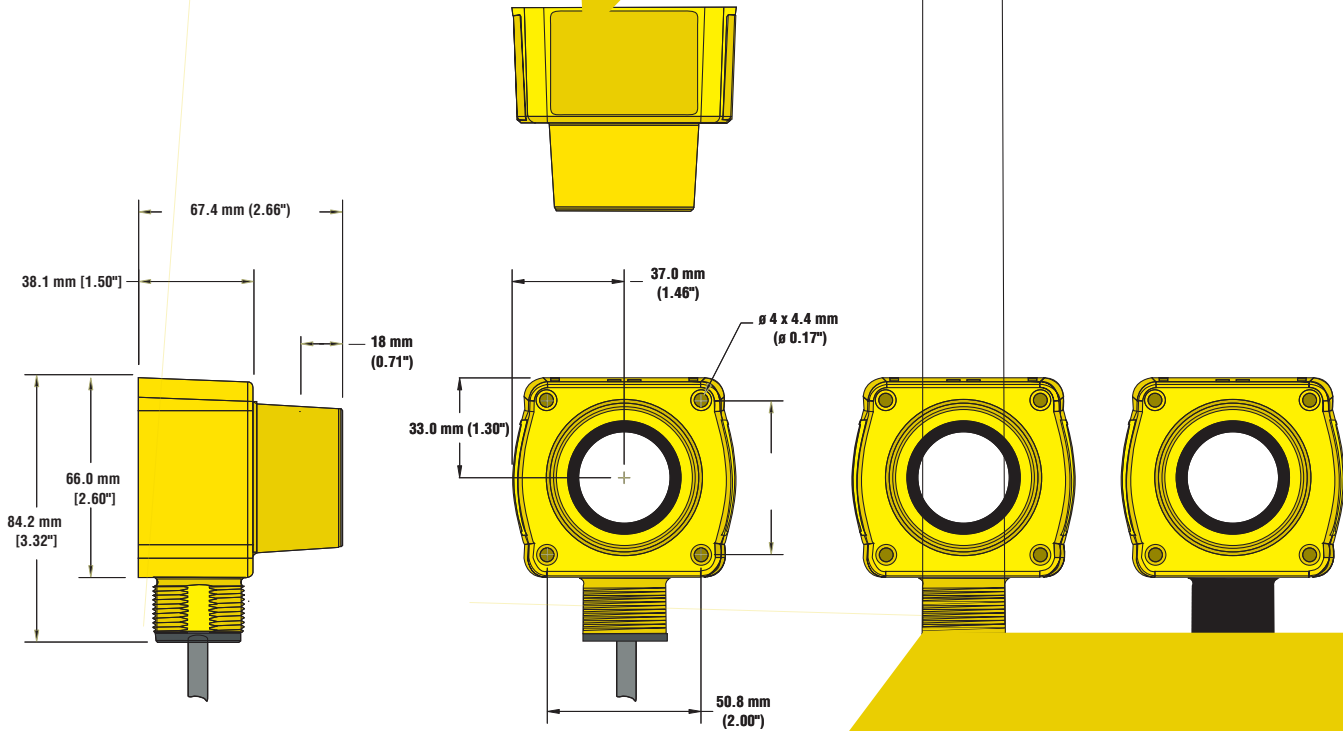

QT50U Sensor Dimensions



Quick-Disconnect

Style	Model	Length
5-Pin Mini with shield	MBCC2-506	2 m (6.5')
	MBCC2-512	4 m (12')
	MBCC2-530	9 m (30')
5-Pin Euro Straight with shield	MQDEC2-506	2 m (6.5')
	MQDEC2-515	5 m (16.4')
	MQDEC2-530	9 m (29.5')
5-Pin Euro Right-angle with shield	MQDEC2-506	2 m (6.5')
	MQDEC2-515	5 m (16.4')
	MQDEC2-530	9 m (29.5')

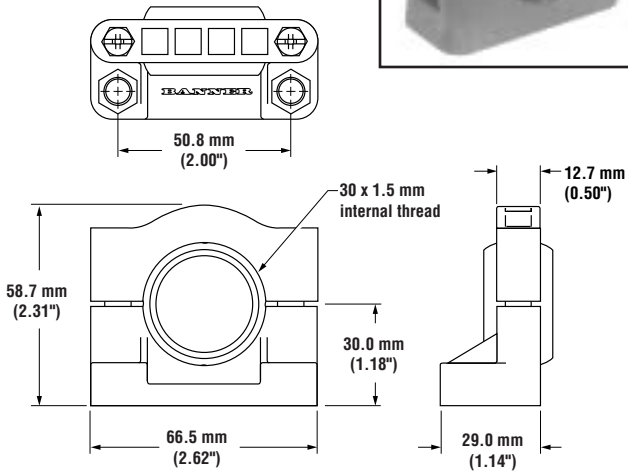
U-GAGE™ QT50U Series Sensor — Analog Output

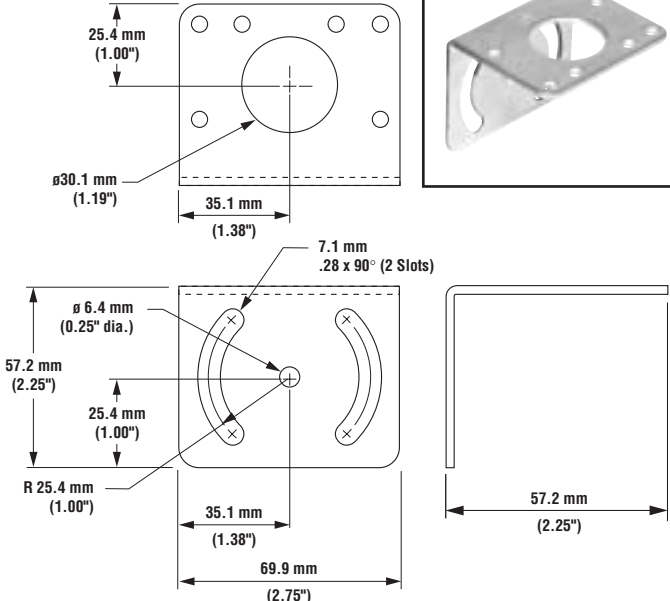
Mounting Brackets			
SMB30SC	<ul style="list-style-type: none"> • 30 mm split clamp with swivel, black reinforced thermoplastic polyester • Stainless steel hardware included 	SMB30MM	<ul style="list-style-type: none"> • 30 mm, 11-gauge, stainless steel bracket with curved mounting slots for versatility and orientation • Clearance for M6 (1/4") hardware
 		 	

U-GAGE™ QT50U Series Sensor — Analog Output



more sensors, more solutions

WARRANTY: Banner Engineering Corp. warrants its products to be free from defects for one year. Banner Engineering Corp. will repair or replace, free of charge, any product of its manufacture found to be defective at the time it is returned to the factory during the warranty period. This warranty does not cover damage or liability for the improper application of Banner products. This warranty is in lieu of any other warranty either expressed or implied.